

WARING**MX1200TX****XPREP® Hi-Power Variable-Speed Food Blender
with 64 oz. BPA-Free Copolyester Container****MAIN FEATURES**

- Heavy-duty, high-performance 3½ peak HP motor with variable-speed selection is the strongest in its class. It powers through the toughest ice and frozen fruit mixtures in seconds.
- Super-high 30,000+ RPM motor speed for the smoothest consistencies.
- Simple ON/Standby and Variable/PULSE paddle switches with variable-speed knob are easy to use and easy to find in a dimly lit location.
- Variable-speed control from 1,500 RPM to 20,000 RPM for maximum control over your blending—perfect for all types of food preparation.
- The Raptor® 64 oz. stackable BPA-free copolyester container.
 - Ultra-aggressive blade and jar design delivers smoother consistencies and faster results
 - Unbreakable, dishwasher-safe construction
- High-performance, high-impact stainless steel blade is user replaceable for easy servicing.
- Easily removable container cover with removable clear cap for adding ingredients and pressure reduction during hot food blending.
- User-replaceable, metal-on-metal stainless steel coupling system between base and container for durability and reliability.
- One-piece, dishwasher-safe, removable jar pad.
- Optional sound enclosure easily retrofits to base for noise reduction.
- Recommended for 75+ cycles per day.
- Limited Three-Year Motor and Two-Year Parts & Labor Warranty.

SALES FEATURES

Get smooth, consistent results every time with the Waring® MX1200TX. This heavy-duty 3½ peak HP blender teams up with The Raptor® blade and jar assembly for maximum power and efficiency. It's ferocious enough for everything from smoothies and frozen drinks to thick spreads, desserts, dressings, and all types of food preparation. Rev it up with variable-speed controls from 1,500 to 20,000 RPM and a max pulse of 30,000+ RPM. Perfect for a busy bar, health facility, school or coffee shop.

ELECTRICAL

Voltage: 120V

Frequency: 60Hz

Watts: 1560W

Amps: 12.5A

Plug Type: NEMA 5-15P























Cord Length: 6 feet

**XPREP® Hi-Power Variable-Speed Food Blender with 64 oz. BPA-Free Copolyester Container****MX1200TX**



XPREP® Hi-Power Variable-Speed Food Blender with 64 oz. BPA-Free Copolyester Container MX1200TX

PARTS & ACCESSORIES

- | | | | |
|---|--|---|--|
|  | CAC90
64 oz. Stainless Steel Container |  | CAC95-12
64 oz. Green Copolyester Container |
|  | CAC93X
48 oz. Copolyester Container |  | CAC95-28
64 oz. Orange Copolyester Container |
|  | CAC93X-03
48 oz. Yellow Copolyester Container |  | CAC116
Blending Assembly Kit and Retainer Ring Kit |
|  | CAC93X-06
48 oz. Blue Copolyester Container |  | CAC119
Retainer Ring Wrench |
|  | CAC93X-10
48 oz. Purple Copolyester Container |  | CAC158
Blending Assembly Kit |
|  | CAC93X-12
48 oz. Green Copolyester Container |  | CAC159
Retainer Ring Kit |
|  | CAC93X-28
48 oz. Orange Copolyester Container |  | CAC182
Drive Coupling |
|  | CAC95
The Raptor™ Aggressive, All-Purpose, Stackable 64 oz. BPA-Free Copolyester Container |  | CAC183
Drive Coupling |
|  | CAC95-03
64 oz. Yellow Copolyester Container |  | CAC161
Drive Coupling Removal Tool |
|  | CAC95-06
64 oz. Blue Copolyester Container |  | CAC169
Spatula – Custom designed for use with MX Series Blenders |
|  | CAC95-10
64 oz. Purple Copolyester Container |  | SE1500
Sound Enclosure |

DIMENSIONS

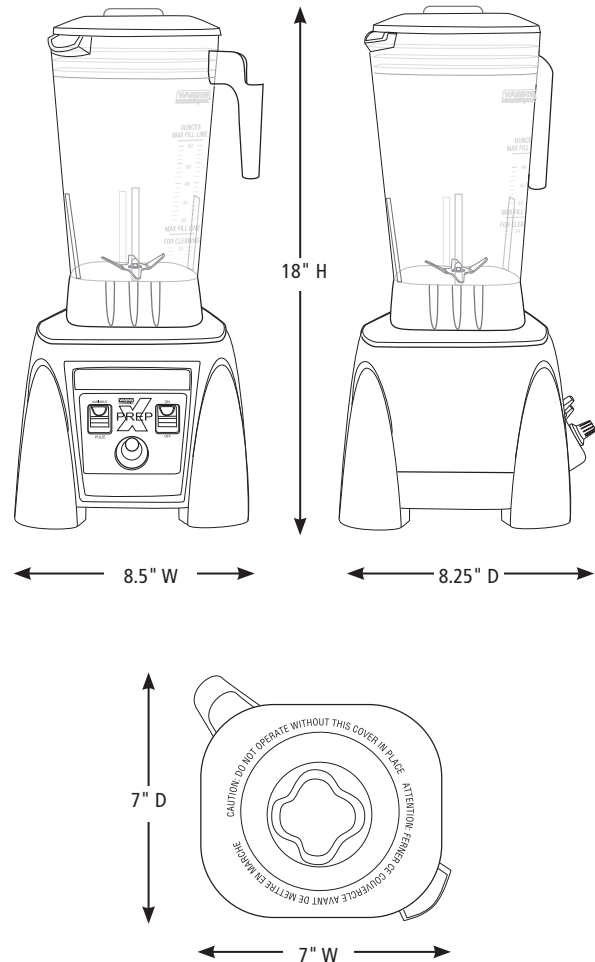

Out-of-Box Weight: 14.64 lb.

ORDERING INFORMATION	#STD. PKG.	GIFTBOX WEIGHT	CUBIC FEET	BOX DIMENSIONS D X W X H	UPC	CASE PKG.	MC WEIGHT	MC DIMENSIONS D X W X H	MBC
MX1200TX– XPREP® Hi-Power Variable-Speed Food Blender with 64 oz. BPA-Free Copolyester Container	1	17.1 lb.	1.043	11.25" x 10.375" x 15.5"	040072017018	1	18.05 lb.	11.75" x 10.875" x 16.25"	10040072017015



WolfLabs

Pricing on any accessories shown can be found by keying the part number into the search box on our website.

The specifications listed in this brochure are subject to change by the manufacturer and therefore cannot be guaranteed to be correct. If there are aspects of the specification that must be guaranteed, please provide these to our sales team so that details can be confirmed.

www.wolflabs.co.uk

Tel : 01759 301142

Fax : 01759 301143

sales@wolflabs.co.uk

Please contact us if this literature doesn't answer all your questions.